



KARNATAKA ICSE SCHOOLS ASSOCIATION

ICSE STD. X Preparatory Examination 2024

Subject: PHYSICS

Maximum Marks: 80

Time Allowed: 2 hours

Date: 29/01/2024

Maximum Marks: 80

Time allowed: Two hours

Answers to this Paper must be written on the paper provided separately.

You will not be allowed to write during first 15 minutes.

This time is to be spent in reading the question paper

The time given at the head of this Paper is the time allowed for writing the answers.

Section A is compulsory. Attempt **any four** questions from **Section B**.

The intended marks for questions or parts of questions are given in brackets []

SECTION A

(Attempt **all** questions from this Section.)

Question 1

Choose the correct answers to the questions from the given options:

[15]

- (i) If F represents the force and d represents distance, then the unit of the product of F and d can be:
- (a) J
 - (b) N m
 - (c) V C
 - (d) All of these
- (ii) 25 J of work is done on a body so that it moves a distance of 5 m. The change in KE of the body is:
- (a) $25 \text{ kg m}^2 \text{ s}^{-2}$
 - (b) $50 \text{ kg m}^2 \text{ s}^{-2}$
 - (c) $125 \text{ kg m}^2 \text{ s}^{-2}$
 - (d) $150 \text{ kg m}^2 \text{ s}^{-2}$

- (iii) The energy change in the bob of a simple pendulum when it moves from the mean position to the extreme position is:
- (a) KE to PE
 - (b) PE to KE
 - (c) Only KE
 - (d) Only PE
- (iv) A ray of light is directed from glass [$n = 1.50$] to water [$n = 1.33$]. What can be concluded about their angle of incidence (i) and angle of refraction (r) ?
- (a) i always equal to r
 - (b) i always greater than r
 - (c) i can be equal to r
 - (d) i always less than r
- (v) A swimming pool with depth t is completely filled with water having refractive index n . The base of the swimming pool will appear to be shifted to:
- (a) $T / (1 - 1/n)$
 - (b) $t (1 - 1/n)$
 - (c) $t + (1 - 1/n)$
 - (d) $t - (1 - 1/n)$
- (vi) Assertion: Microwaves travel with the speed of light.
Reason: Microwave is an electromagnetic wave.
- (a) both assertion and reason are true
 - (b) both assertion and reason are false
 - (c) assertion is false but reason is true
 - (d) assertion is true but reason is false

- (vii) A ray of light experiences total internal reflection while entering from medium A to medium B. Then:

option	Refractive index of:	angle of incidence is:
(a)	A is greater than B	less than the critical angle
(b)	A is less than B	equal to the critical angle
(c)	A is greater than B	greater than the critical angle
(d)	A is less than B	equal to the critical angle

- (viii) The characteristics of sound which enables to differentiate between two sounds of different waveform is:

- (a) Loudness
- (b) Pitch
- (c) Quality
- (d) Frequency

- (ix) The number of vibrations made by two waves M and N, in a given time interval, is represented as shown below.

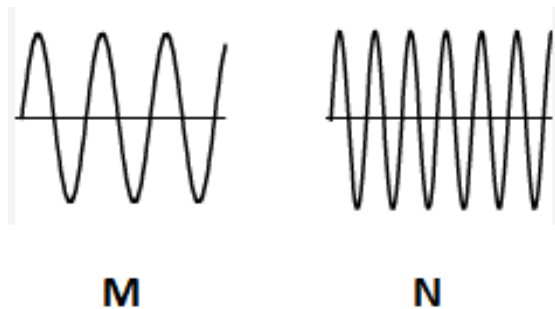

What can be concluded about M and N?

- (a) M is louder than N
- (b) N is louder than M
- (c) M is shriller than N
- (d) N is shriller than M

- (x) The V-I graph for a conductor at two temperatures- T_1 and T_2 - is as shown below.

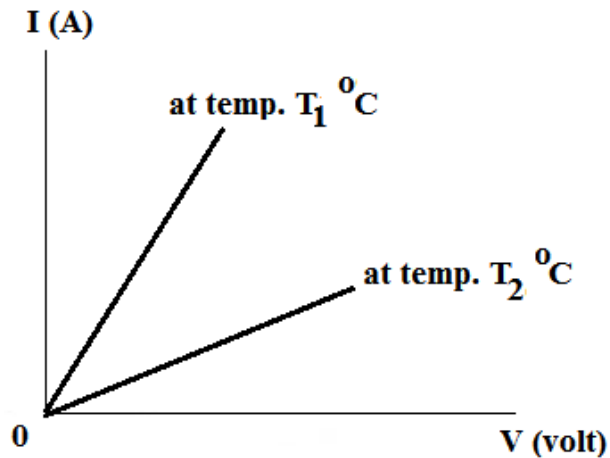

What can be concluded about T_1 and T_2 ?

- (a) $T_1 > T_2$
 - (b) $T_1 < T_2$
 - (c) $T_1 = T_2$
 - (d) Insufficient data to make the conclusion
- (xi) Two fuse wires E and F are marked 5A and 15 A respectively. Then:
- (a) E is thicker than F
 - (b) E is thinner than F
 - (c) E and F are of the same thickness
 - (d) None of these
- (xii) The direction of the induced current in a conductor moving in an external magnetic field can be found out using:
- (a) Lenz's law
 - (b) Fleming's left hand rule
 - (c) Fleming's right hand rule
 - (d) Right hand thumb rule

- (xiii) During change of state, remains constant.
- (a) Temperature and volume
 - (b) Volume and mass
 - (c) Mass and temperature
 - (d) Volume and temperature
- (xiv) If P represents the mass of a body, Q and R represents its specific heat capacity and heat capacity respectively, then:
- (a) $Q = R/P$
 - (b) $R = P/Q$
 - (c) $P = Q/R$
 - (d) None of these
- (xv) α , β and γ are the three radioactive radiations. The correct way to arrange them in the ascending order of their ionization power is:
- (a) $\alpha < \beta < \gamma$
 - (b) $\gamma < \beta < \alpha$
 - (c) $\beta < \alpha < \gamma$
 - (d) $\beta < \gamma < \alpha$

Question 2

- (i) A metre scale is balanced at its centre of gravity which is found to be at 60 cm mark. Represent this using a neat labelled diagram. What weight kept at the end of longer arm will balance an object weight 120 gf kept at the other end? [3]
- (ii) The centre of gravity of a body depends on two factors. Name them. [2]
- (iii) A ball is dropped from a height of 10 m. If acceleration due to gravity at that place is 9.8 m s^{-2} , calculate the velocity with which the ball hits the ground. [2]
- (iv) Name the class of lever having a velocity ratio always greater than 1. Give an example for such a lever. [2]
- (v) Give two points of differences between free vibrations and damped vibrations. [2]

- (vi) How does the internal resistance of a cell depends on:
- The temperature of the cell
 - The concentration of the electrolyte [2]
- (vii) A radioactive element E undergoes α disintegration followed by two β disintegrations, to form the final product F. For the element E, the atomic number and mass number are Z and A respectively. Write the values of the atomic number and mass number of the element F. What is the general name given to E and F? [2]

Question 3

- What are the two characteristics required for the material of a fuse wire? [2]
- The earth pin in a 3pin plug is made longer and thicker. Give reason. [2]
- List two ways to increase the force acting on a conductor placed in an external magnetic field B. [2]
- 80 g of material M at 60°C is mixed with 20 g of material N at 30°C . If the specific heat capacity of N is double than that of M, calculate the resultant temperature of the mixture. [2]
- The diagram below shows the heating curve for certain material. [2]

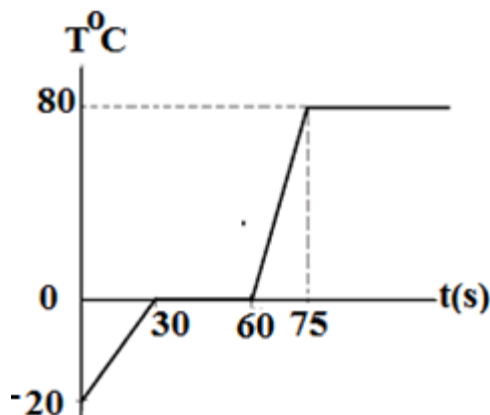

- State the time taken by the material to melt completely.
- What is the boiling point of this material?

SECTION B

(Attempt *any four* questions.)

Question 4

- (i) You are provided with a load, three pulleys and one string. Arrange the pulleys such that a minimum effort is applied to lift the load. Represent it in the form of a diagram. Clearly label the diagram. [3]
- (ii) The diagram below shows the graphical relation between angle of deviation and angle of incidence, when light passes through a triangular prism with angle of the prism A .

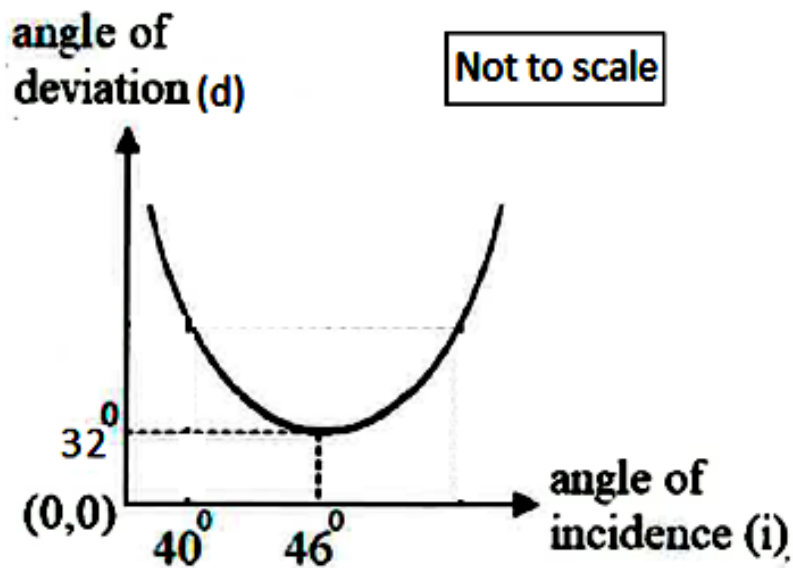

Study the graph and answer the following questions:

- (a) Calculate the angle of the prism A . [2]
- (b) With reference to the base of the glass prism, what can be predicted about the direction of the refracted ray within the prism, when the angle of deviation is 32° ? [1]

- iii) Consider the circuit diagram below to answer the questions that follows: [4]

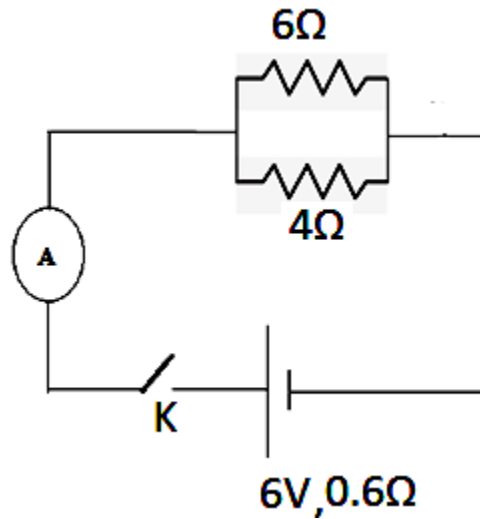

Calculate resistance of the circuit when the key K is:

- i) Open.
- ii) Closed
- iii) What is the reading in the ammeter A?
- iv) Current through the 4Ω resistor = _____.

Question 5

- (i) (a) Write the equation relating mechanical advantage MA, velocity ratio VR and efficiency η . [1]
(b) Among MA, VR and η , which quantity remains constant for a machine of given design. Give reason for your answer. [2]
- (ii) The specific heat capacities of two liquids L and M are C_L and C_M respectively. C_M is much greater than C_L . [3]
 - (a) Define specific heat capacity.
 - (b) Among Land M, identify the liquid that will be preferred as coolant.
 - (c) Give reason for your choice.

- (iii) The displacement-distance graph and the displacement-time graph for a wave is shown below:

displacement(m)

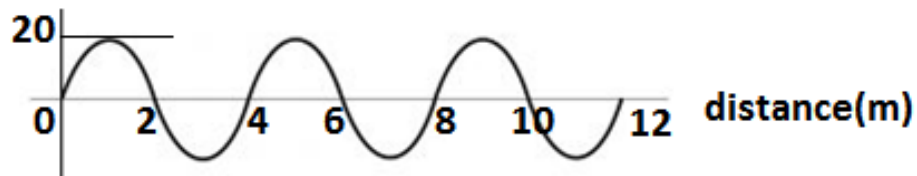

displacement(m)

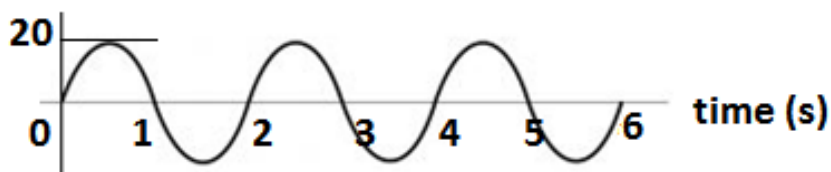

Use the graph to calculate the :

- wavelength of the wave
- frequency of the wave
- speed of the wave
- amplitude of the wave

[4]

Question 6

- (i) A radioactive nucleus undergoes a series of decays according to the sequence:

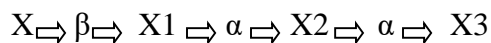

If the mass number and atomic number of X_3 are 172 and 69 respectively, what is the

mass number and atomic number of X_2 , X_1 and X ?

[3]

- (ii) A ray of light passes through a glass block as shown below. Predict the possible values for angles i and r . What is the lateral deviation for the ray? [3]

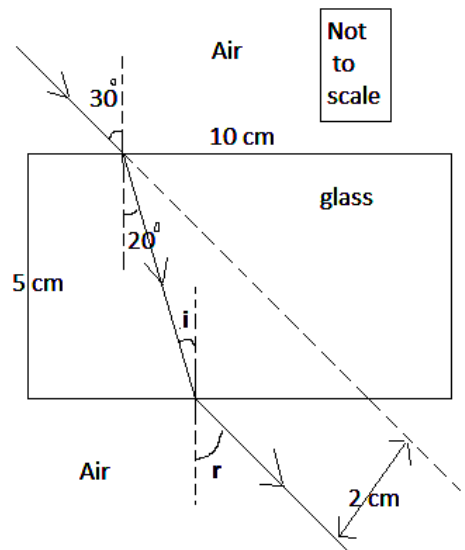

- (iii) For a science exhibition, two students A and B brought two similar exhibits. Both the exhibits consist of a coil placed in the magnetic field. Student A rotates the coil and a bulb connected to it glows. Student B passes current through the coil and the coil rotates.
- Name the phenomena involved with the exhibit of student A.
 - State the principle based on which the exhibit of student B works.
 - List the application of the above exhibits in daily life.
- [4]

Question 7

- (i) A transformer is used to transmit electrical energy from the generating station. A transformer basically consists of a core, primary windings and secondary windings. It is an integral part of many low- power applications. Depending on the necessity, a step-up transformer or a step-down transformer is used in a circuit.
- For a step-up transformer, what can be predicted about the thickness of the primary coil with reference to that of the secondary coil.
 - What is the working principle of a transformer?
 - The electrical energy transmission from a generating station is at high volt. Why? [3]

- (ii) A man is standing at a distance d from a cliff. He claps and hears the echo in 3 s. He moves 170 m away from the cliff. At this position, the echo is heard after 4s. Calculate the distance d . [3]
- (iii) (a) In the following arrangement, a magnetic material M is attracted towards the coil PQ. Identify the magnetic polarity induced at the end P of the coil. Justify your answer with a suitable reason. [2]

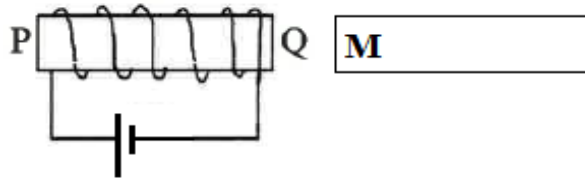

- (b) A magnet NS is moved away from the coil RS as shown below. A deflection is shown in the galvanometer. Give a reason for this phenomena. Predict the polarity that will be induced at the end R in the arrangement. [2]

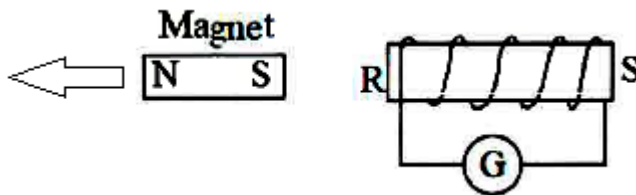

Question 8

- (i) (a) Give the new convention for the colour code of live wire.
 (b) Two components in a circuit are always connected in series with the live wire. Name them. [3]
- (ii) An object of height 20 cm is placed in front of a lens at a distance of 25 cm. Its virtual, magnified image is formed at a distance of 50 cm.
 (a) Identify the type of the lens.
 (b) Calculate the size of the image.
 (c) The focal length of the lens must be greater than _____ cm [3]

- (iii) The diagram below shows an object O placed in front of a convex lens.

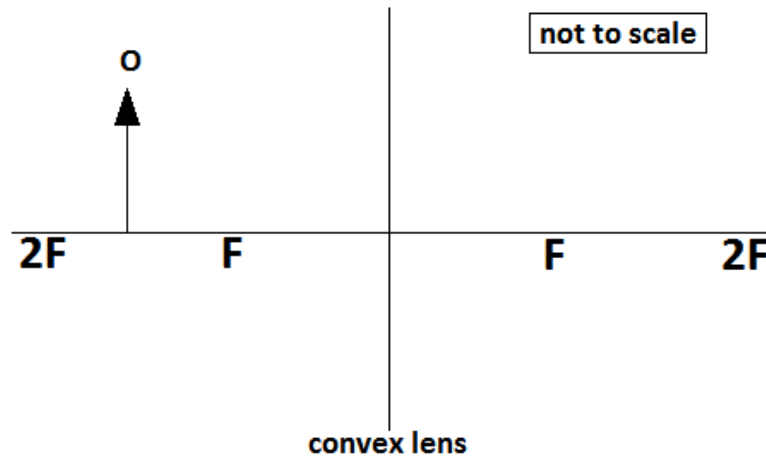

Redraw and complete the ray diagram showing the formation of the image. Write any one characteristics of the image formed. [4]

Question 9

- (i) (a) Specific latent heat of ice = 336 J g^{-1} . What does this mean?
(b) The ice on the top of mountains never melt all together. Why?
(c) We prefer ice to ice-cold water for cooling a drink. Why? [3]
- (ii) (a) State one safety precaution in the disposal of nuclear waste.
(b) For a given mass of nuclear fuel, the energy released during a nuclear fusion reaction is more than that during the nuclear fission reaction. Give reason.
(c) Give an example for an internal source and an external source of background radiation. [3]
- (iii) (a) A violet ray of light is directed from air to a glass block. The speed of light in air and in glass is $3 \times 10^8 \text{ ms}^{-1}$ and $2 \times 10^8 \text{ ms}^{-1}$ respectively.
Calculate the refractive index of glass.
(b) If the wavelength of violet colour is 450 nm in air,
calculate its wavelength when it enters the glass block.
(c) What will be the ratio : $\frac{\text{frequency of the violet light in air}}{\text{frequency of the violet light in glass}}$
Give reason for your answer. [4]